

AWK-4121 Series

Industrial IEEE 802.11a/b/g outdoor wireless AP/Bridge/Client



The certification logos shown here apply to some or all of the products in this section. For details, see "Regulatory Approvals" under "Specifications" below.

- > IEEE 802.11a/b/g compliant
- > Redundant power inputs and PoE
- > Higher security with WEP/WPA/WPA2/802.11X and powerful filter
- > Turbo Roaming™ for seamless wireless connections
- > Long-distance communication support
- > Wide operating temperature range and IP67-rated metal housing for hazardous environments



Introduction

The AWK-4121 outdoor wireless AP/Bridge/Client is an ideal 3-in-1 solution for industrial applications that are hard to wire, too expensive to wire, or use mobile equipment that connects to a TCP/IP network. The AWK-4121 can operate at temperatures ranging from -40 to 75°C, and its dust-tight and weatherproof design is IP67-rated and allows you to set up a WLAN, or extend existing wired networks to outdoor locations. In addition, the AWK-4121 is equipped with detachable antennas so it can give you the flexibility of choosing your own special-purpose antennas. The AWK-4121's two redundant DC power inputs increases the reliability of the power supply. It can also be powered via PoE and is easy to deploy.

Specifications

WLAN Interface

Standards:

IEEE 802.11a/g/b for Wireless LAN
 IEEE 802.11i for Wireless Security
 IEEE 802.3u for 10/100BaseT(X)
 IEEE 802.3af for Power-over-Ethernet
 IEEE 802.1D for Spanning Tree Protocol
 IEEE 802.1w for Rapid STP

Spread Spectrum and Modulation (typical):

- DSSS with DBPSK, DQPSK, CCK
- OFDM with BPSK, QPSK, 16QAM, 64QAM
 64QAM @ 54 Mbps, 16QAM @ 24/36 Mbps, QPSK @ 12/18 Mbps,
 CCK @ 11/5.5 Mbps, DQPSK @ 2 Mbps, DBSK @ 1 Mbps

Operating Channels (central frequency):

US:

2.412 to 2.462 GHz (11 channels)
 5.18 to 5.24 GHz (4 channels)

EU:

2.412 to 2.472 GHz (13 channels)
 5.18 to 5.24 GHz (4 channels)

JP:

2.412 to 2.472 GHz (13 channels, OFDM)
 2.412 to 2.484 GHz (14 channels, DSSS)
 5.18 to 5.24 GHz (4 channels for W52)

Security:

- SSID broadcast enable/disable
- Firewall for MAC/IP/Protocol/Port-base filtering
- 64-bit and 128-bit WEP encryption, WPA/WPA2 Personal and Enterprise (IEEE 802.1X/RADIUS, TKIP and AES)

Ruggedized Design for Critical Environments

- IP67-rated metal housing
- Waterproof and dust-tight RJ45 connectors
- M12 connectors protect against shock and vibration
- Hardened mounting kit for flexible installation outdoors

Specifications for Industrial-grade Applications

- Turbo Roaming™ for rapid handover during client roaming
- Long-distance data transmission over 10 km
- Integrated DI/DO for on-site monitoring and warning
- Status LED indicators for on-site monitoring and diagnosis

Transmission Rates:

802.11b: 1, 2, 5.5, 11 Mbps

802.11a/g: 6, 9, 12, 18, 24, 36, 48, 54 Mbps

TX Transmit Power:

802.11b:

Typ. 18±1.5 dBm @ 1 to 11 Mbps

802.11g:

Typ. 18±1.5 dBm @ 6 to 24 Mbps, Typ. 16±1.5 dBm @ 36 to 48 Mbps, Typ. 15±1.5 dBm @ 54 Mbps

802.11a:

Typ. 16±1.5 dBm @ 6 to 24 Mbps, Typ. 14±1.5 dBm @ 36 to 48 Mbps, Typ. 13±1.5 dBm @ 54 Mbps

RX Sensitivity:

802.11b:

-92 dBm @ 1 Mbps, -90 dBm @ 2 Mbps, -88 dBm @ 5.5 Mbps, -84 dBm @ 11 Mbps

802.11g:

-87 dBm @ 6 Mbps, -86 dBm @ 9 Mbps, -85 dBm @ 12 Mbps, -82 dBm @ 18 Mbps, -80 dBm @ 24 Mbps, -76 dBm @ 36 Mbps, -72 dBm @ 48 Mbps, -70 dBm @ 54 Mbps

802.11a:

-87 dBm @ 6 Mbps, -86 dBm @ 9 Mbps, -85 dBm @ 12 Mbps, -82 dBm @ 18 Mbps, -80 dBm @ 24 Mbps, -76 dBm @ 36 Mbps, -72 dBm @ 48 Mbps, -70 dBm @ 54 Mbps

Protocol Support

General Protocols: Proxy ARP, DNS, HTTP, HTTPS, IP, ICMP, SNMP, TCP, UDP, RADIUS, SNMP, RTP

AP-only Protocols: ARP, BOOTP, DHCP, dynamic VLAN-Tags for 802.1X-Clients, STP/RSTP (IEEE 802.1D/w)

Interface

Default Antenna: 5 dBi, 2.4 GHz omni-directional antenna, N-type (male)

Connector for External Antenna: N-type (female)

LAN Port: 10/100BaseT(X) auto negotiation speed (waterproof RJ45-type)

Console Port: RS-232 (waterproof RJ45-type)

LED Indicators: PWR, FAULT, STATE, WLAN, LAN

Alarm Contact (Digital Output, M12 connector): 1 relay output with current carrying capacity of 1 A @ 24 VDC

Digital Inputs (M12 connector): 2 electrically isolated inputs

- +13 to +30 V for state "1"
- +3 to -30 V for state "0"
- Max. input current: 8 mA

Physical Characteristics

Housing: Metal, IP67 protection

Weight: 1.2 kg

Dimensions: 224 x 147.7 x 66.5 mm (8.82 x 5.82 x 2.62 in)

Installation: Wall mounting (standard), DIN-Rail mounting (optional), pole mounting (optional)

Environmental Limits

Operating Temperature: -40 to 75°C (-40 to 167°F)

Storage Temperature: -40 to 85°C (-40 to 185°F)

Ambient Relative Humidity: 5% to 95% (non-condensing)

Power Requirements

Input Voltage: 12 to 48 VDC, redundant dual DC power inputs or 48 VDC Power-over-Ethernet (IEEE 802.3af compliant)

Connector: M12 connector with A-coding

Power Consumption:

- 0.121 to 0.494 A @ 12 to 48 VDC
- 0.3 A @ 24 VDC

Reverse Polarity Protection: Present

Regulatory Approvals

Safety: EN60950-1, UL60950-1

Radio: EN300 328, EN301 893, ARIB STD-33/T66/T71 (Japan)

EMC: EN301 489-1/-17, FCC Part 15, EN55022/55024, IEC61000-6-2/-4

Environmental/EMC Compliance: EN50155, EN50121-1/-4, Directive 72/245/EEC (for e/M mark)

Note: Please check Moxa's website for the most up-to-date certification status.

Warranty

Warranty Period: 5 years

Details: See www.moxa.com/warranty

Dimensions

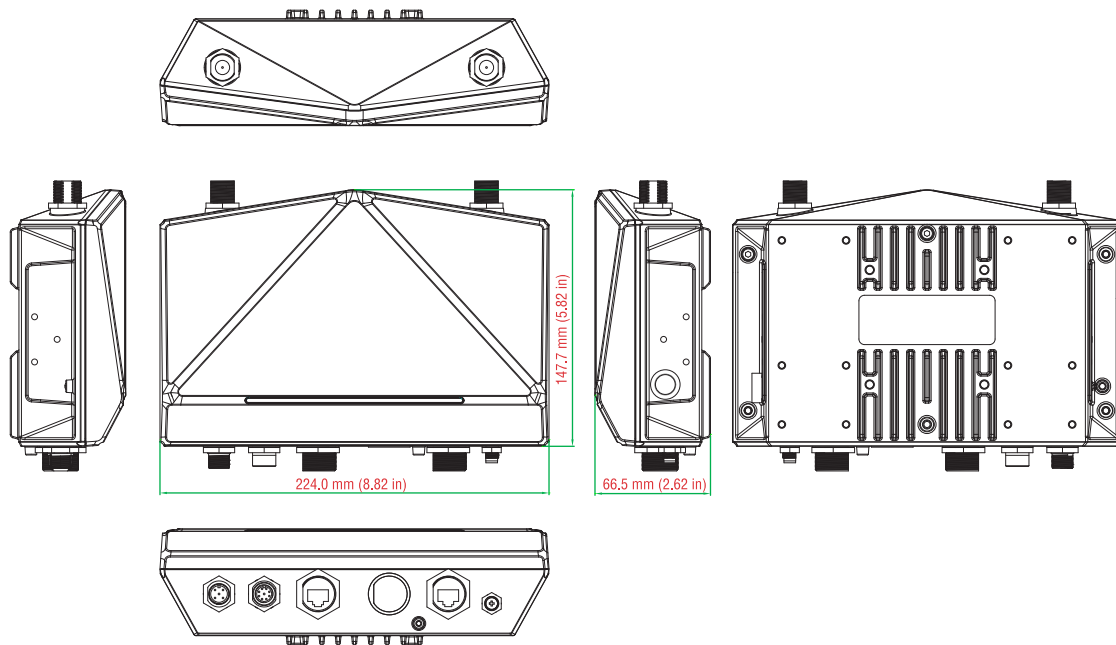

Ordering Information

Available Models

AWK-4121-US-T: IEEE 802.11a/b/g outdoor wireless AP/Bridge/Client, US band, -40 to 75°C operating temperature

AWK-4121-EU-T: IEEE 802.11a/b/g outdoor wireless AP/Bridge/Client, EU band, -40 to 75°C operating temperature

AWK-4121-JP-T: IEEE 802.11a/b/g outdoor wireless AP/Bridge/Client, JP band, -40 to 75°C operating temperature

Optional Accessories (can be purchased separately)

M12A-5P-IP68: Field-installable A-coded screw-in sensor connector, male

M12A-8P-IP68: Field-installable A-coded screw-in 8-pin connector, female

PLG-WPRJ: Field-installable RJ-type plug

DK-DC50131: Din-Rail mounting kit, 50 x 131 mm

PK-DC2D0F: Pole-mounting kit

CRF-N0429N-3M: CFD400 cable, N-type male to N-type male, 3 meters

Note: Please visit Moxa's website for a complete list of optional accessories available for these products.