



technetix

empowering broadband networks

www.technetix.com

Technetix Group

Communications House
Edward Way, Burgess Hill
West Sussex, RH15 9TZ
United Kingdom
+44 (0)1444 251 200
+44 (0)1444 258 555
info@technetix.com

**Quick Install and Link Set-up Guide for
UCA-6120 - UCA-6120/RV**

Quick Install and Link Set-up Guide for UCA-6120 - UCA-6120/RV

Introduction

The Adapt-x series of UTP to Coax Adapters offer an economical solution to use a coaxial cable for the transport of Ethernet signals. A 100 Mbps Full Duplex connection can be made without the 100 m length limitation of Cat 5e cable and with additional remote powering up to 70 Watt.

Depending of the type of coaxial cable, distances of over 350 m can be achieved without problems. This technology offers new opportunities to upgrade analogue CCTV cameras with IP and Mega Pixel cameras without changes of the cabling infrastructure. A very fast deployment at minimal cost, both in investment and cost of ownership is possible. PTZ cameras and heating systems at the far end can be remotely powered via the coaxial cable.

The Adapt-x series consist of 3 field models to make remote powered 100 Mbps links:

UCA-6120	Adapter, with remote powering.
UCA-6120/RV	Adapter, with remote powering and build in SMPS (regulated voltage).
UCA-6124/PoE	Adapter, with remote powering and 4 port switch with PoE.
UCA-6820	8 ports Adapter, with remote powering - mountable in 19" rack
UCA-6220/R	In line Power over coax (PoC) repeater

This quick guide will explain the technology and instruct how to set up a link with: UCA-6120 - UCA-6120/RV

Where the UCA-6120 is used at the central location and the UCA-6120/RV at the far end.

For more applications visit www.technetix.com or www.adapt-x.com

UCA-6120 Interface and connectors.

Referring to the picture:

On the top of the housing is placed the DC power connector.

Pin 1 and 2 are DC input or output. They are connected to the BNC connector at the front. Pin 3 and 4 are system ground.

At the front the 10/100 Mbps connections are placed RJ-45 and BNC female connectors. The BNC connector is also the DC input / output for the remote powering.

At the bottom the DIP switch is located to adjust the settings. See DIP switch settings Table 1.

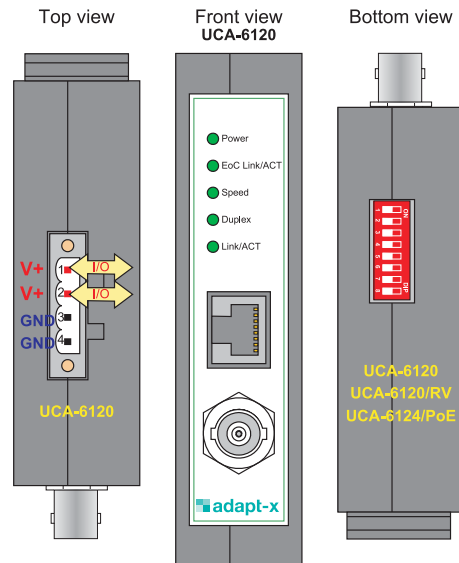

Technical specifications UCA-6120

Standards	: 802.3 / 802.3 U / 802.3 X	
Interfaces		
Ethernet	: 10/100 BaseT	RJ-45 Connector
Coaxial	: 10/100 Mbps	BNC female 75 Ohm
Power	: 4 pole screw terminal	

Voltage and currents		
Pin 1 Input / output voltage	: 15 .. 60 V DC	at max current of 1.2 Amp.
Pin 2 Input / output voltage	: 15 .. 60 V DC	at max current of 1.2 Amp.
BNC Input / output voltage	: 15 .. 60 V DC	at max current of 1.2 Amp.
Power consumption	: 2.4 Watt (Vin at Pin 1 = 15 V DC minimal)	

Operating temperature : -25 ... +70 °C

Coaxial Link distance		
RG-59/BU	: > 150 m @ 100 Mbps / FD	
RG-11	: > 350 m @ 100 Mbps / FD	

Remark: these values are indications and depend on the coaxial cable type and quality.

Technical specifications UCA-6120/RV

Standards	: 802.3 / 802.3 U / 802.3 X	
Interfaces		
Ethernet	: 10/100 BaseT	RJ-45 Connector
Coaxial	: 10/100 Mbps	BNC female 75 Ohm
Power	: 4 pole screw terminal	

Voltage and currents		
Pin 1 Input / output voltage	: 15 .. 60 V DC	at max current of 1.2 Amp.
Pin 2 output voltage	: Selectable 5 – 9 - 12 – 24 VDC	at max current of 1.0 Amp.
Pin 2 output current	: max current of 1.0 Amp.	
BNC Input / output voltage	: 15 .. 60 V DC	at max current of 1.2 Amp.
Power consumption	: 2.4 Watt (at V in Pin 1 = 15 V DC minimal)	

Operating temperature : -25 ... +55 °C

Coaxial Link distance:		
RG-59/BU	: > 150 m @ 100 Mbps / FD	
RG-11	: > 350 m @ 100 Mbps / FD	

Remark: these values are indications and depend on the coaxial cable type and quality.

How to build a connection UCA-6820 – UCA-6120/RV & UCA-6124/PoE

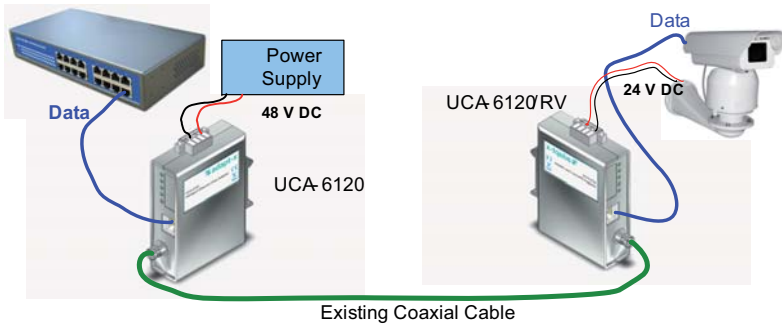

- Check if the coaxial cable is in good condition and that the BNC connectors are properly mounted, use an Ohm meter to check if there are no short circuits. In case of doubt, short circuit the coax at the far end and measure with Ohm meter the DC resistance of the cable. This also gives indication of the cable length, check with the cable manufacturer specification.
- For a RG-59 type of cable a loop resistance of 10 to 20 Ohm per 100m is quite normal. With copper clad steel cables the loop resistance may be significantly higher.
- As an example a link with a remote camera with powering via the coax is used. For this a UCA-6120 is used at the central location and a UCA-6120/RV is used at the far end.
- Mount the UCA-6120/RV vertical to a DIN rail.(optional)
- Connect a coaxial cable to the BNC connector at the front.
- Select the correct output voltage from the UCA-6120/RV with the DIP switch setting at the bottom. (check the UCA-6120/RV quick guide for the correct settings)
- Connect the camera power cable to the DC connector at the UCA-6120/RV, use Pin 2 Output and Pin 3 and 4 for system ground.



Warning ! The full supply voltage is always at PIN 1!!!!

- Check the DIP switch settings for correct speed and duplex mode setting.
- Connect the camera via the RJ45 connector at the front using a standard patch cable.
- Mount the UCA-6120 vertical to a DIN rail.(optional)
- Mount the Power Supply to the DIN rail(optional)
- Connect the coaxial cable to the BNC connector at the front.
- Connect the DC power from the Power Supply to Pin 1 from the UCA-6120 and Pin 3 and 4 for system ground. Use the supplied connector / terminal block for this.

- Switch on the Power Supply.
- On the UCA-6120/RV at the far end the Power LED should light up.
- If the LED does not light up the voltage might be too low.
- Check the incoming voltage at Pin 1 of the power connector of the UCA-6120/RV.
- The voltage must be a minimum of 6 Volt higher than the requested output voltage at Pin 2.
- So to feed a 24 V DC camera the voltage at Pin 1 must be $24 + 6 = 30$ V minimum.

- The LED EoC Link/ACT should light up and you know the link is made.
- Connect the RJ45 from the UCA-6120 at the central location to the application server and watch the camera picture.

Table 1 - DIP switch settings UCA-6120

DIP Switch	Function	ON	OFF	Remark
1	Auto negotiation	Disabled	Enabled	
2	RJ-45 Duplex mode	Full Duplex	Half Duplex	1
3	RJ-45 Speed	100 Mbps	10 MBps	2
4	Coax Speed	100 Mbps	10 Mbps	
5	Coax Duplex mode	Full Duplex	Half Duplex	
6	Reserved	Keep switch in OFF position		
7	LED indicators	Enabled	Disabled	
8	Reserved	Keep switch in OFF position		

Remark:

1. When DIP Switch 1 is ON, this switch DIP Sw 2 will not work.
2. When DIP Switch 1 is ON, this switch DIP Sw 3 will not work.

Principle of operation

In the below block diagram the principle of operation is explained.

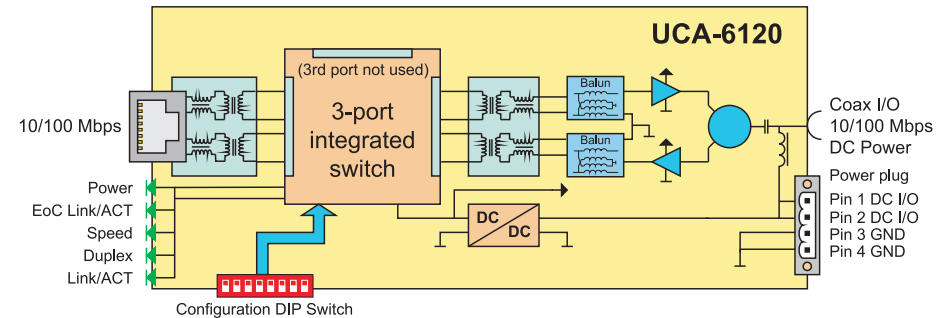

The Ethernet signal at the RJ-45 port is fed via a switch to the coaxial part. Using a balun and a splitter the 100 ohm symmetrical signal is converted to a 75 ohm a-symmetrical signal. The amplifiers compensate the splitter and balun loss. The input power at Pin 1 and 2 is directly fed to the BNC connector to power the far end unit and connected to the internal DC/DC converter to feed the amplifiers and the switch.



Do not connect a higher voltage than 60 V DC to the input. The minimum voltage for the UCA-6120 to work is 15 V DC. Do not connect an external DC voltage or the Input voltage to Pin2. The maximum current for the BNC connector is 1.2 Amp. Do not exceed this max current and voltage to avoid irreparable damage.

The LED indicators at the front of the unit indicate the status:

Table 2 - UCA-6120 - LED indicators description

Indicator	LED	Function
Power		When 15 to 60 V DC is connected it will light up green
EoC Link/ACT		Indicates Coax link activity: ON = link Active Blinking = Traffic
Speed		Indicates Ethernet Speed: ON = 100 Mbps OFF = 10 Mbps
Duplex		Indicates duplex status ON = Full duplex OFF = Half duplex.
Link/Act		Indicates RJ-45 link activity: ON = link Active Blinking = Traffic

UCA-6120/RV Interface and connectors.

Referring to the picture:

On the top of the housing is placed the DC power connector.
Pin 1 is the DC input or output and is connected to the BNC connector at the front.
It is also connected to the built-in SMPS. The output voltage of the SMPS is on Pin 2.
See DIP switch setting below to select the voltage.
Pin 3 and 4 are system ground.

At the front the 10/100 Mbps connections are placed the RJ-45 and BNC female connectors. .
The BNC connector is also DC input / output for the remote powering.

At the bottom the DIP switch is located to adjust the settings. See DIP switch settings Table 3 below.

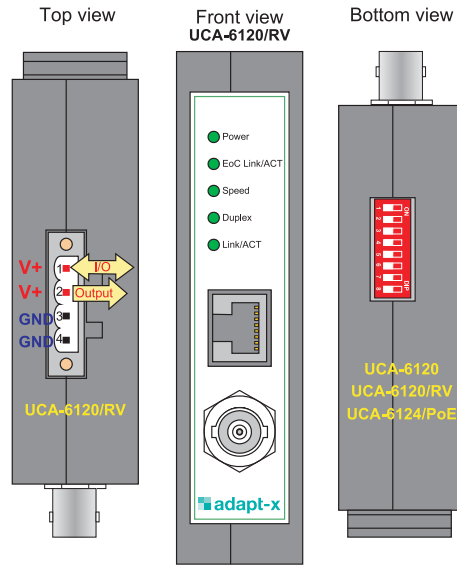

Table 3 - DIP switch settings UCA-6120/RV

DIP Switch	Function	ON	OFF	Remark	
1	Auto negotiation	Disabled	Enabled		
2	RJ-45 Duplex mode	Full Duplex	Half Duplex	1	
3	RJ-45 Speed	100 Mbps	10 Mbps	2	
4	Coax Speed	100 Mbps	10 Mbps		
5	Reserved	Keep switch in OFF position			
6	Output Voltage setting	OFF	ON	ON	
7	Output Voltage setting	OFF	OFF	ON	
8	Output Voltage setting	OFF	OFF	ON	
	Voltage on Pin 2	5 V	9 V	12 V	24 V

Remark:

- When DIP Switch 1 is ON, this switch DIP Sw 2 will not work.
- When DIP Switch 1 is ON, this switch DIP Sw 3 will not work.

Principle of operation

In the below block diagram the principle of operation is explained.

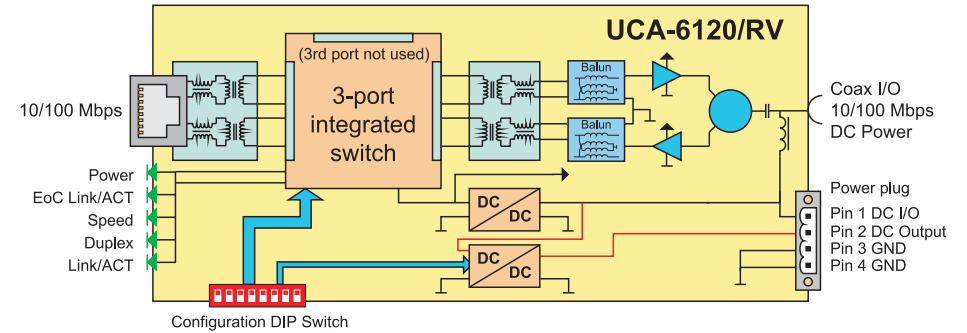

The only difference between the UCA-6120 and the UCA-6120/RV is the built-in SMPS (Switch Mode Power Supply). It works identical as the UCA-6120 for the Ethernet part.

The input power at Pin 1 is directly fed to the BNC connector to power the far end unit and connected to the internal DC/DC converter to feed the amplifiers and the switch. It is also connected to the SMPS. This is a DC/DC converter which makes an adjustable DC voltage of 5-9-12 or 24 Volt which can be used to power a camera or other device. Internally the input voltage is measured and compared with the output voltage, when it is too low to guarantee the output voltage the Power LED will no longer light up.

The Ethernet link may be fine but the input voltage is probably too low. To be sure keep the input voltage on Pin 1 at least 6 V higher than the selected output voltage at Pin 2.



Do not connect a higher voltage than 60 V DC to the input. The minimum voltage for the UCA-6120/RV to work is 15 V DC. Do not connect an external DC voltage or the input voltage to Pin 2. The maximum current for the BNC connector is 1.2 Amp. Do not exceed this max current and voltage to avoid irreparable damage

The LED indicators at the front of the unit indicate the status:

Table 4 - UCA-6120/RV - LED indicators description

Indicator LED	Function
Power	When 15 to 60 V DC is connected it will light up green When the Input voltage at Pin 1 / BNC connector is high enough for the selected output voltage at Pin 2 the LED will light up.
EoC Link/ACT	Indicates Coax link activity: ON = link Active Blinking = Traffic
Speed	Indicates Ethernet Speed: ON = 100 Mbps OFF = 10 Mbps
Duplex	Indicates duplex status ON = Full duplex OFF = Half duplex.
Link/Act	Indicates RJ-45 link activity: ON = link Active Blinking = Traffic